

## XPlate™ Customer Success Story - TCRSS

TCRSS, a large steel manufacturing plant in Thailand with gas combustion furnaces, achieved a 12% reduction in gas use through installation of XPlate™ technology. ROI was achieved in less than 6 months and the XPlate™ continues to save TCRSS money today.

### XPlate™ technology

XPlate™ (Xenogenic Plate) is the result of over 10 years of intense research into the patented molecular Xenogenic-fuel technology. It is a device that is easily installed at locations such as power plants, steel plants or any site that uses industrial boilers. Installation requires no down time whatsoever, because XPlate™ is installed on the outside of existing pipe work.

Improved combustion efficiency and reduced emissions are achieved through installing XPlate™ due to its ability to store a natural charge which is then released as fuel or air passes through the treated pipe. This technology has been proved to be effective by many government and private organisations across Europe and Asia Pacific.

The effects of XPlate™ are on a molecular and microscopic particle scale, as illustrated below:

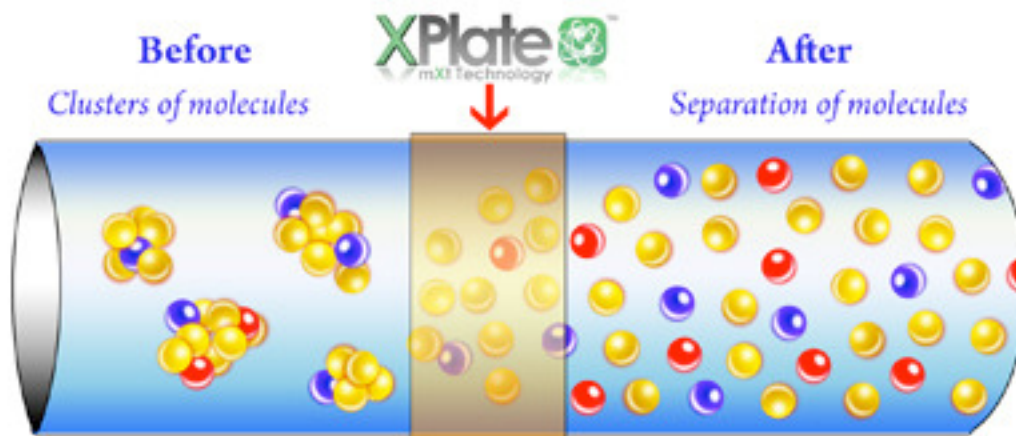

### Gas-Fired Combustion

At TCRSS, the XPlate™ was installed on gas-fired combustion equipment, including industrial boilers, steel furnaces, and heating-required chemical reactors. The results consistently show a higher combustion efficiency, which results in a significant reduction of gas consumption and lower CO<sub>2</sub> emissions.



## The Customer -

TCRSS is a large, established, Asian steel manufacturing company that produce cold rolled steel sheets. TCRSS employ over 800 staff and have a manufacturing capacity of 1 million tonnes of rolled steel per annum. The manufacturing plant covers an area of 370,000 square meters. The plant utilises a Base Annealing Furnace (BAF).

## The trial

An industrial test was performed on XPlate™ at TCRSS. XPlate™ sheets were installed on both the air combustion (two locations) and gas pipelines.

The molecular clusters of air (oxygen and nitrogen) and gas, after passing through XPlate™, are broken down, leaving single molecules of oxygen, nitrogen, and gas. (Coal may not be completely broken down to single molecules due to other variables, such as humidity, flow rate, etc.). XPlate™ was installed only at the burner compartment section.

## Xplate Installation Location Diagram

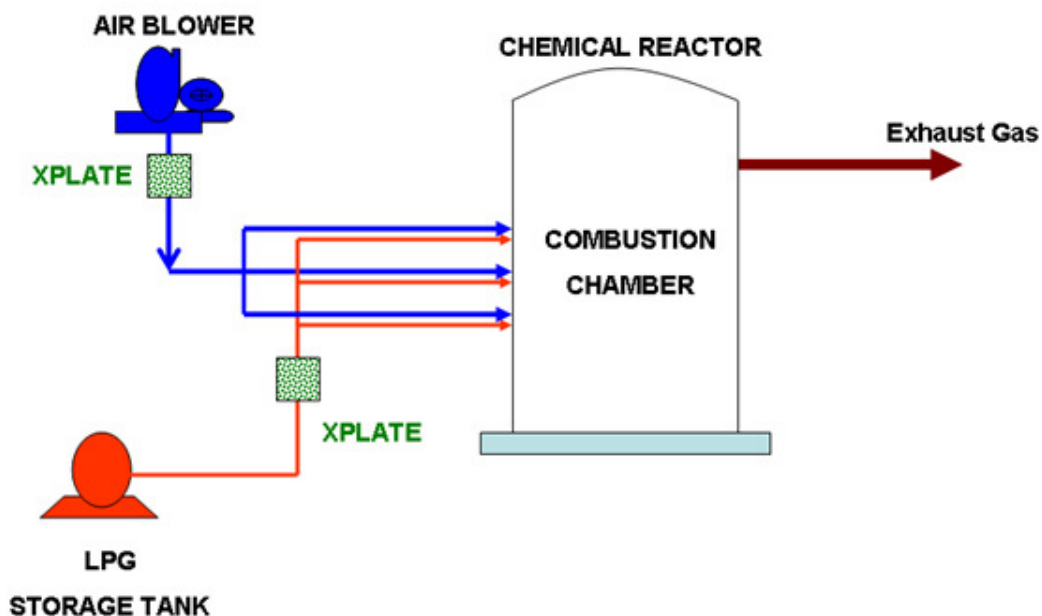

## **XPlate™ Results for TCRSS – 12% efficiency**

After the installation of XPlate™, there was an increase in flame brightness from the combustion of gas and oxygen at the burner, indicating the temperature and energy increased as a result of the XPlate™ installation.

The mobile furnace selected for the test was performing in peak condition, both prior and during the test. After installing XPlate™, and after the engineer had adjusted the flow rates of gas and air, gas consumption saving was calculated to be 12.0%. See Appendix A and B worksheets for details.

This is a great result for TCRSS. The Return On Investment for the XPlate™ installation means that it has paid for itself with 6 months. The XPlate™ will continue to save TCRSS for years to come.





## Appendix C

### XPlate™ design information (for heating furnace unit)

Parameters	Approximate Value (Unit)
<b>1. Pipe Characteristics (LPG Line)</b>	
Material Type	Stainless Steel
Outer Perimeter	25 cm.
Lower LPG Line for XPLATE area	25 cm. x 35 cm.
Upper LPG Line for XPLATE area	
Number of LPG Lines	1 main, split LPG into 10 burners
Piping Distance from Storage tank to nozzle head	200 m.
<b>2. Pipe Characteristics (Air Line)</b>	
Material Type	Stainless Steel
Outer Perimeter (Straight Line)	60 cm.
Air Line for XPLATE area	60 cm. x 60 cm.
Blower for XPLATE area	25 cm. x 110 cm.
Number of Air Lines	1 Blower, split air into 10 lines
Piping Distance from blower to nozzle head	10 m.
Is there any insulation?	NO
<b>3. Fuel Gas Properties</b>	
Name of Gas	LPG
Maximum Gas Flow rate	700 Nm <sup>3</sup> per 15 hours
Normal Gas Flow rate	400 - 500 Nm <sup>3</sup> per 15 hours
Gas Density	
Gas Pressure	
Gas Temperature	
Gas Heating Value	
<b>4. Air Properties</b>	
Blower Model / Manufacturer	
Power of Air Blower	
Maximum Air Flow rate	
Normal Air Flow rate	
Air Density	
Air Pressure	
Air Temperature	30 C
<b>5. Other Relevant Properties</b>	
Current combustion ration air : fuel	
Ambient Temperature	30 C
Exhaust Stack Temperature	
Exhaust reactor Temperature	
<b>6. Banner</b>	DO NOT REMOVE XPLATE DESIGNED FOR TCRSS at BAF ONLY



---

TK Fuels Pty Ltd ABN 251 30600998

3 Spring Street, Sydney, NSW, 2000, Australia T +61(0)2 8249 4649 F +61(0)2 8240 4001 [www.tkfuels.com.au](http://www.tkfuels.com.au)