

# **Energy Saving Project with Xplate<sup>tm</sup> for**

**Thai Cold Rolled Sheet Steel Public  
Company Limited**

# **Contents**

1. Company Profile
2. Plant and Installation of Xplate
  - 2.1. Xplate Design Information
  - 2.2. Location of Xplate installation
3. Test Results
  - 3.1. Flame Changes at the Burner
  - 3.2. Gas Savings

Appendices: Signed results data sheets

# 1. Company Profile

Thai Cold Rolled Steel Sheet Public Company Limited  
**Base Annealing Furnace (BAF)**

111 Moo 4, Maeramphueng, Bangsaphan, Prachuabkirikhan 77140  
THAILAND

Website: [www.tcrss.co.th](http://www.tcrss.co.th)

**TCRSS**  
THAI COLD ROLLED STEEL SHEET PUBLIC COMPANY LIMITED

HOME MAIL TORSS LINKS SITE MAP

About Us || Products || Achivement || News Room || Annual Report || Careers || Procurement || Safety & Environment || Contact

ENGLISH ไทย

**Welcome to TCRSS**

TCRSS is proud to be the first cold rolled steel sheet manufacturer in Thailand. Our product , perfectly reflect our total commitment to excellence in quality, which is supported by the world class technological resources and the newest equipment from JFE, Japanese leading steel maker. This website is designed to provide information for the customers and the public to get to know us of our product, vision and mission, community concerns and our commitment.

**NEWS**

- บริษัท ไทยคอลลด์โรลด์สตีลชีท จำกัด คว้ารางวัลชนะเลิศ...  
ทุนส่งออก : Oct 20, 2006
- ราคาสแลนปรับผิวขึ้นขณะที่ HRC ยังนิ่งในเอเชีย  
ตะวันออกเฉียงใต้ : Apr 20, 2006
- โรงเหล็กจีนเร่งกระชับความร่วมมือกับเราซิด : Apr 12, 2006
- Gerdau AmeriSteel ซื้อ Sheffield Steel ของ  
สหรัฐฯ : Apr 12, 2006

**C S R**

- บริษัทจากคอมพิวเตอร์เพื่อการศึกษา : Oct 24, 2006

**STEEL CLINIC**

**STEEL LAB**

Copyright © 2006 Thai Cold Rolled Steel Sheet Public Co., Ltd. All rights reserved.

## 2. Plant and Installation of XPlate™

An industrial test was performed on XPlate™ at Thai Cold Rolled Steel Sheet Co. Ltd. (TCRSS), Prachub kilikarn Province, Thailand (Figures 1-2). XPlate™ sheets were installed on both the air combustion and gas pipe lines.

The molecular clusters of air (oxygen and nitrogen) and gas, after passing through XPlate™, are broken down, leaving single molecules of oxygen, nitrogen, and gas. (Coal may not be completely broken down to single molecules due to other variables, such as humidity, flow rate, etc.) XPlate™ was installed only at the burner compartment section.

Figure 1: Thai Cold Rolled Steel Sheet Co., Ltd. (TCRSS)





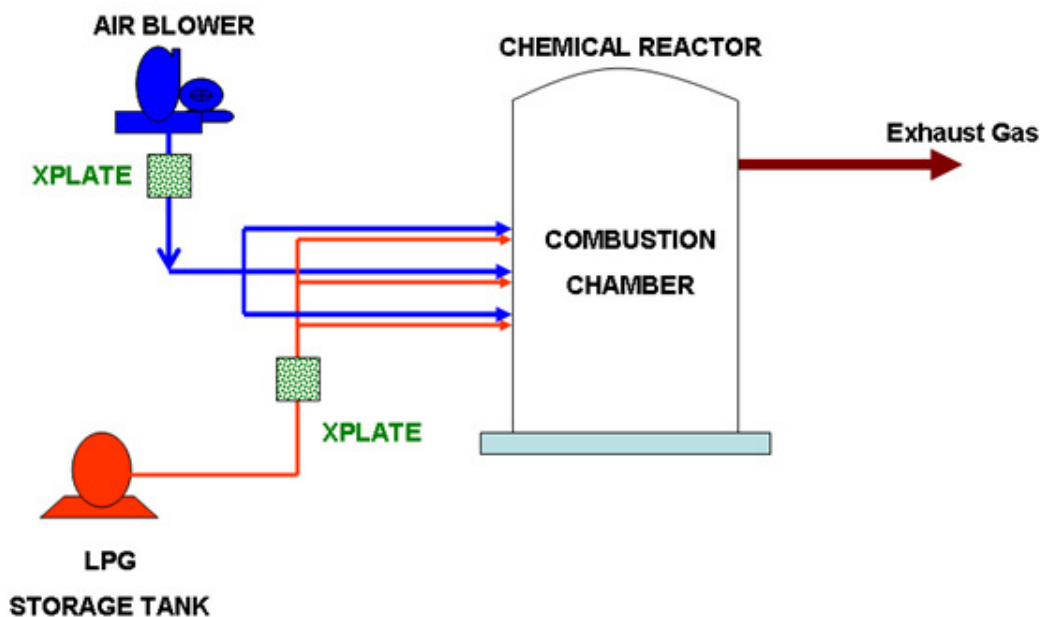

Xplate Installation Location



## 2.1. XPlate™ design information (for heating furnace 1 unit)

Parameters	Approximate Value (Unit)
<b>1. Pipe Characteristics (LPG Line)</b>	
Material Type	Stainless Steel
Outer Perimeter	25 cm.
Lower LPG Line for XPLATE area	25 cm. x 35 cm.
Upper LPG Line for XPLATE area	
Number of LPG Lines	1 main, split LPG into 10 burners
Piping Distance from Storage tank to nozzle head	200 m.
<b>2. Pipe Characteristics (Air Line)</b>	
Material Type	Stainless Steel
Outer Perimeter (Straight Line)	60 cm.
Air Line for XPLATE area	60 cm. x 60 cm.
Blower for XPLATE area	25 cm. x 110 cm.
Number of Air Lines	1 Blower, split air into 10 lines
Piping Distance from blower to nozzle head	10 m.
Is there any insulation?	NO
<b>3. Fuel Gas Properties</b>	
Name of Gas	LPG
Maximum Gas Flow rate	700 Nm <sup>3</sup> per 15 hours
Normal Gas Flow rate	400 - 500 Nm <sup>3</sup> per 15 hours
Gas Density	
Gas Pressure	
Gas Temperature	
Gas Heating Value	
<b>4. Air Properties</b>	
Blower Model / Manufacturer	
Power of Air Blower	
Maximum Air Flow rate	
Normal Air Flow rate	
Air Density	
Air Pressure	
Air Temperature	30 C
<b>5. Other Relevant Properties</b>	
Current combustion ration air : fuel	
Ambient Temperature	30 C
Exhaust Stack Temperature	
Exhaust reactor Temperature	
<b>6. Banner</b>	DO NOT REMOVE XPLATE DESIGNED FOR TCRSS at BAF ONLY

## 2.2. Location of XPlate™ installation

Location	BEFORE	AFTER
(1) Combustion Air Blower (2 places)	 A photograph showing a large industrial combustion air blower with a complex network of yellow-painted pipes and metal walkways. The blower is a large, cylindrical unit with various access points and structural supports.	 A photograph showing the same combustion air blower after the XPlate™ installation. A blue and white cylindrical XPlate™ unit is now mounted vertically on the blower's structure, integrated into the piping system.
(2) Gas Line (1 place)	 A photograph showing a section of a gas line with yellow-painted pipes, valves, and gauges. The pipes are arranged in a vertical and horizontal configuration within an industrial setting.	 A photograph showing the same gas line section after the XPlate™ installation. A blue and white cylindrical XPlate™ unit is mounted on the vertical pipe, positioned between two horizontal pipe sections.

### 3. Test Results

The test results in this report were collected after XPlate™ was installed on each batch.

#### 3.1. Flame changes at the burner

After the installation of XPlate™, the resulting flame brightness from the combustion of gas and oxygen at the burner can be observed in Figures 3 and 4.

Figure 3: Location of flame behind the burner



Figure 4: Flame changes at the burner



It can clearly be seen that the flame is brighter in the “after” pictures, which indicates the temperature and energy increases as a result of the XPlate installation.

#### 3.2. Gas Savings

The mobile furnace selected for test was performing in peak condition prior to the test. After installing XPlate, and after the engineer had adjusted the flow rates of gas and air, as shown in the following data sheets, it was found that gas consumption was reduced 12.0% and 18.2% , respectively.







